

**3-BIN SORTER**  
**(Machine Code: A566)**  
**Service Manual**

---

# 1. SPECIFICATIONS

Paper Size for Bins:	Sort/Stack Modes: Maximum: A3, 11 x 17" Minimum: A6 lengthwise, 5 1/2 x 8 1/2"
Paper Weight for Bins:	Face up: 1st bin: 52 ~ 157 g/m <sup>2</sup> (14 ~ 42 lb) 2nd/3rd bins: 52 ~ 105 g/m <sup>2</sup> (14 ~ 28 lb) Face down: All bins: 64 ~ 105 g/m <sup>2</sup> (17 ~ 28 lb)
Bin Capacity:	1st bin: A4, 8 1/2 x 11" : 500 copies A3, 11 x 17" : 250 copies 2nd/3rd bins: A4, 8 1/2 x 11" : 250 copies A3, 11 x 17" : 125 copies
Number of Bins:	3 copy trays 1 inverter tray
Power Source:	DC 24 V, 5 V (from the main machine)
Power Consumption:	Average: Less than 30 W
Weight:	13 kg (28.7 lb)
Dimensions (W x D x H):	361 x 483 x 427 mm (14.2" x 19.0" x 16.8")

## 2. COMPONENT LAYOUT

### 2.1 MECHANICAL COMPONENT LAYOUT

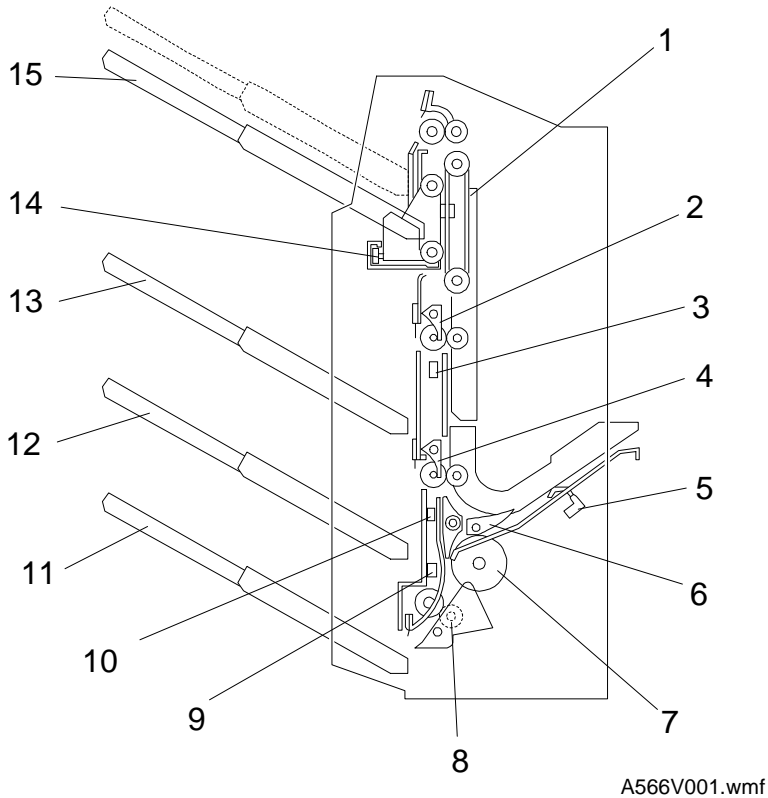

- |                        |                             |
|------------------------|-----------------------------|
| 1. Tray Lift Belt      | 9. Inverter Sensor          |
| 2. 2nd Bin Gate        | 10. 3rd Exit Sensor         |
| 3. 2nd Exit Sensor     | 11. Inverter Bin            |
| 4. 3rd Bin Gate        | 12. 3rd Bin                 |
| 5. Entry Sensor        | 13. 2nd Bin                 |
| 6. Junction Gate       | 14. Tray Lower Limit Sensor |
| 7. Feed Roller         | 15. 1st Bin                 |
| 8. Return Pinch Roller |                             |

## 2.2 DRIVE LAYOUT

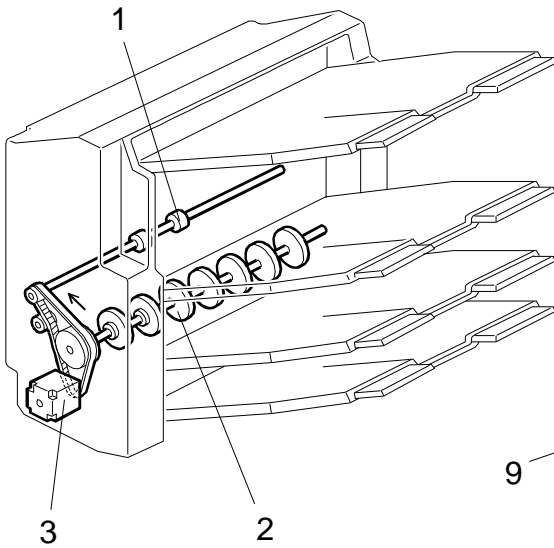

A566V002.wmf

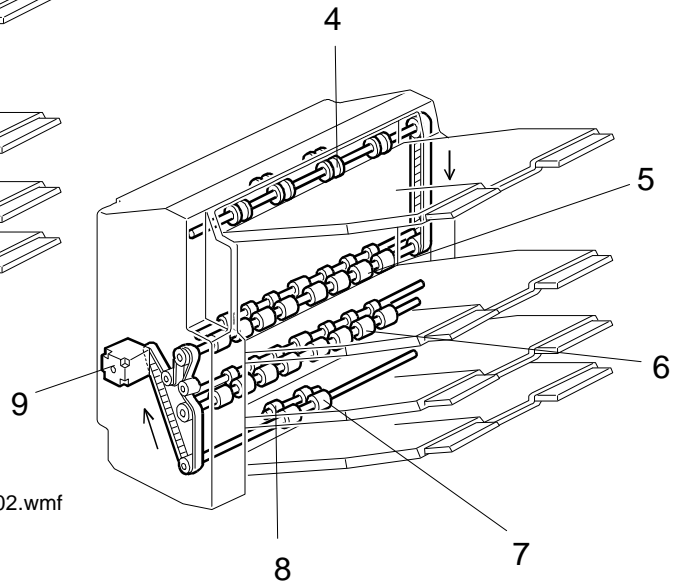

A566V003.wmf

- |                    |                        |
|--------------------|------------------------|
| 1. Entry Roller    | 6. 3rd Exit Roller     |
| 2. Feed Roller     | 7. Inverter Roller     |
| 3. Entrance Motor  | 8. Return Pinch Roller |
| 4. 1st Exit Roller | 9. Exit Motor          |
| 5. 2nd Exit Roller |                        |

## 2.3 ELECTRICAL COMPONENT DESCRIPTION

Refer to the electrical component layout on the reverse side of the point-to-point diagram (on waterproof paper).

Symbol	Index No.	Description	Note
<b>Motors</b>			
M1	13	Entrance	Drives the feed roller and the entry roller.
M2	14	Exit	Drives the inverter roller and the exit rollers.
M3	18	Tray Shift	Moves the 1st bin from side to side.
M4	16	Tray Lift	Moves the 1st bin up or down.
<b>Solenoids</b>			
SOL1	4	2nd Bin Gate	Opens and closes the 2nd bin gate to direct the copies into either the 2nd bin or 1st bin.
SOL2	5	3rd Bin Gate	Opens and closes the 3rd bin gate to direct the copies into either the 3rd bin or the other bins.
SOL3	6	Junction Gate	Opens and closes the junction gate to direct copies into either the inverter area or other exits.
SOL4	7	Pinch Roller	In face down mode, contacts the return pinch roller with the copy to deliver the copy to bin 1, 2, or 3.
<b>Sensors</b>			
S1	2	Stack Height	Detects when the copy paper stack is at the correct height, and detects when the 1st bin is at its upper limit position.
S2	17	Tray Half-turn	Detects complete side-to-side movement of the 1st bin.
S3	1	1st Exit	Detects paper jams at the 1st bin.
S4	8	2nd Exit	Detects paper jams at the 2nd bin.
S5	9	3rd Exit	Detects paper jams at the 3rd bin.
S6	10	Inverter	Detects misfeeds and synchronizes the inverter gate.
S7	11	Entry	Detects misfeeds and copy paper entry.
S8	15	Tray Lower Limit	Detects when the 1st bin is at its lower limit position.
<b>Switches</b>			
SW1	3	Sorter Set	Detects when the sorter is attached to the main machine.
<b>Circuit Board</b>			
PCB1	12	Control	Controls all sorter functions.

## 3. DETAILED SECTION DESCRIPTIONS

### 3.1 BASIC OPERATION

#### 3.1.1 Face-up Mode

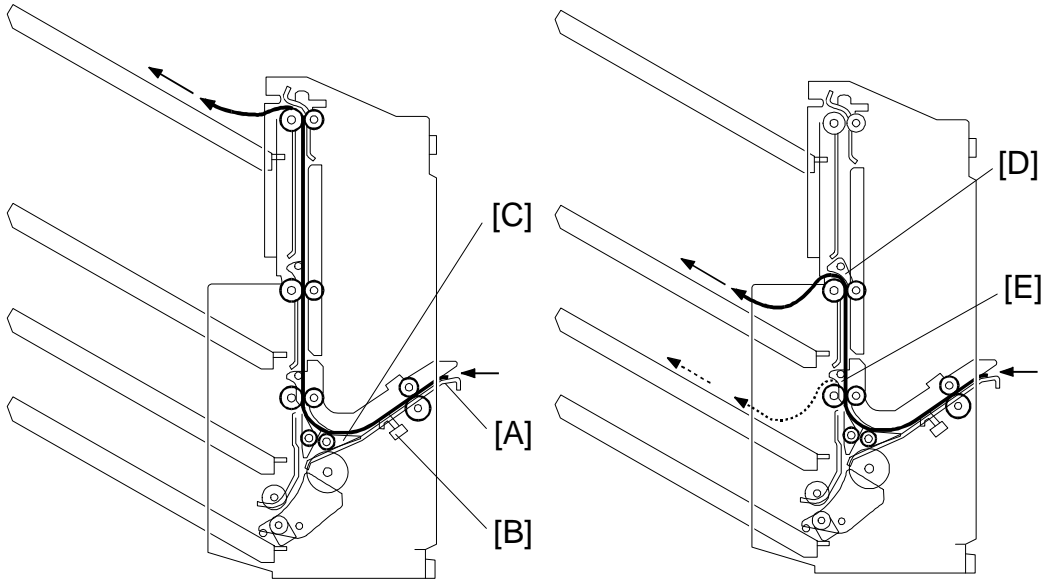

A566D001.wmf

A566D002.wmf

Copies exiting the copier pass through the entrance guide plate [A]. The entry roller will send copies either to the inverter bin or to each bin, depending on the selected mode.

When the sorter receives the feed-out signal from the main machine, the entrance motor and exit motor energize to rotate the all rollers in the sorter. During copying, all rollers transport the paper at a speed which depends on the copier. When the leading edge of the copy passes the entry sensor [B], the speed of the rollers changes to 550 mm/s.

#### - 1st, 2nd and 3rd bins -

When the junction gate [C] is closed as shown above, the copies pass through the upper part of the junction gate. For 1st bin output mode, the copy goes straight up from the junction gate directly to the bin. For the 2nd and 3rd bins, the copies from the junction gate are delivered to these bins, as directed by the 2nd bin gate [D] and 3rd bin gate [E].

**3.1.2 Face-down mode**

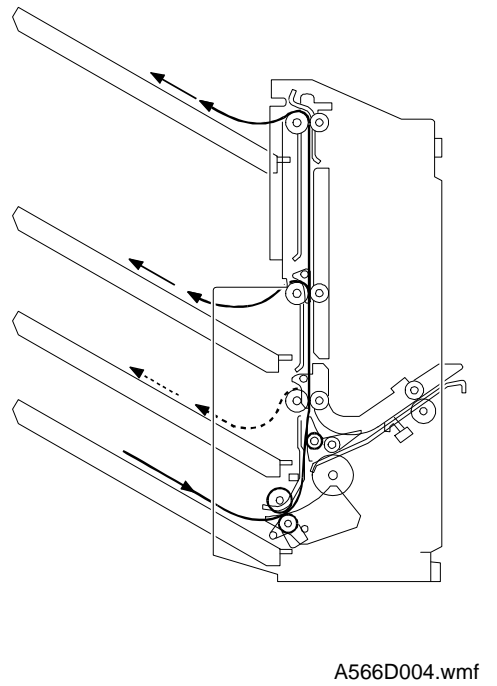
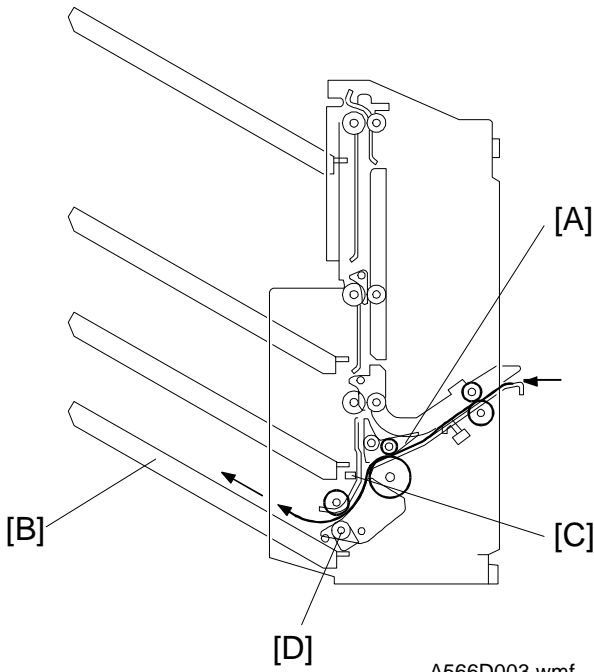

When the junction gate [A] is opened, the copy goes to the inverter bin [B] through the lower part of the junction. When the trailing edge of the copy passes through the inverter sensor [C], the return pinch rollers [D] lower to contact the copy, then the copy is fed back in by the rollers. The copy is fed out to any output bin and it arrives face down.

### 3.2 1ST BIN UP/DOWN MECHANISM

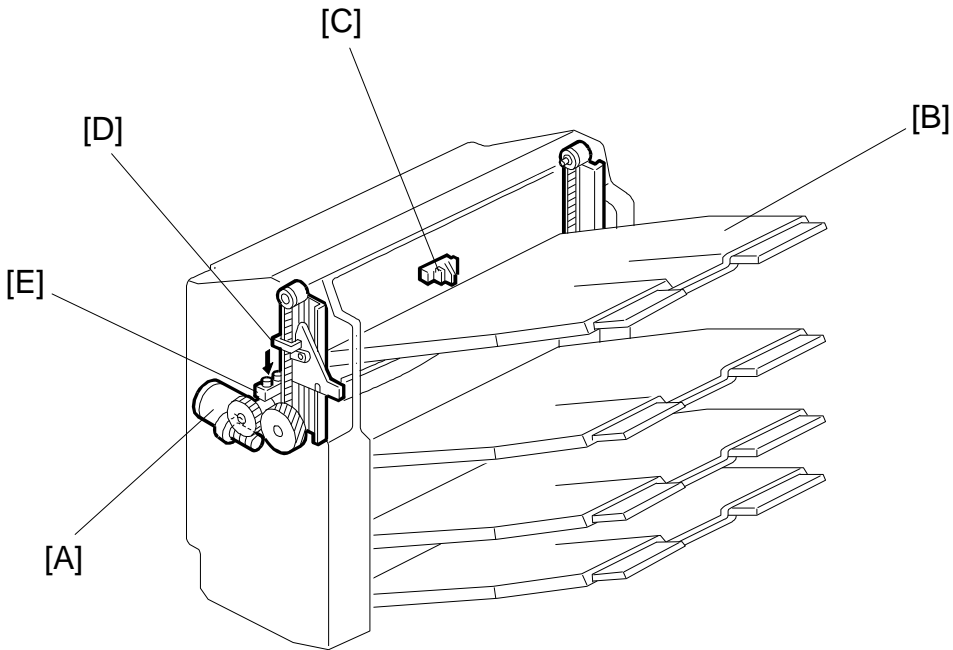

A566D005.wmf

The tray lift motor (a dc motor) [A] controls the vertical position of the 1st bin [B] through gears. When the main switch is turned on, the 1st bin is initialized at the upper position. The bin's upper position is detected by the stack height sensor [C]. The 1st bin activates the stack height sensor, then the 1st bin lowers until it is at the correct height to receive the copy. This initialization is performed before every copy job.

During copying, when the stack height sensor is activated by the stack of paper, the 1st bin lowers until the stack height sensor is deactivated.

When the 1st bin reaches its lower limit, actuator [D] enters the lower limit sensor [E], and copying stops. After copying ends, the machine stops.



### 3.3 1ST BIN SIDE-TO-SIDE SHIFT MECHANISM

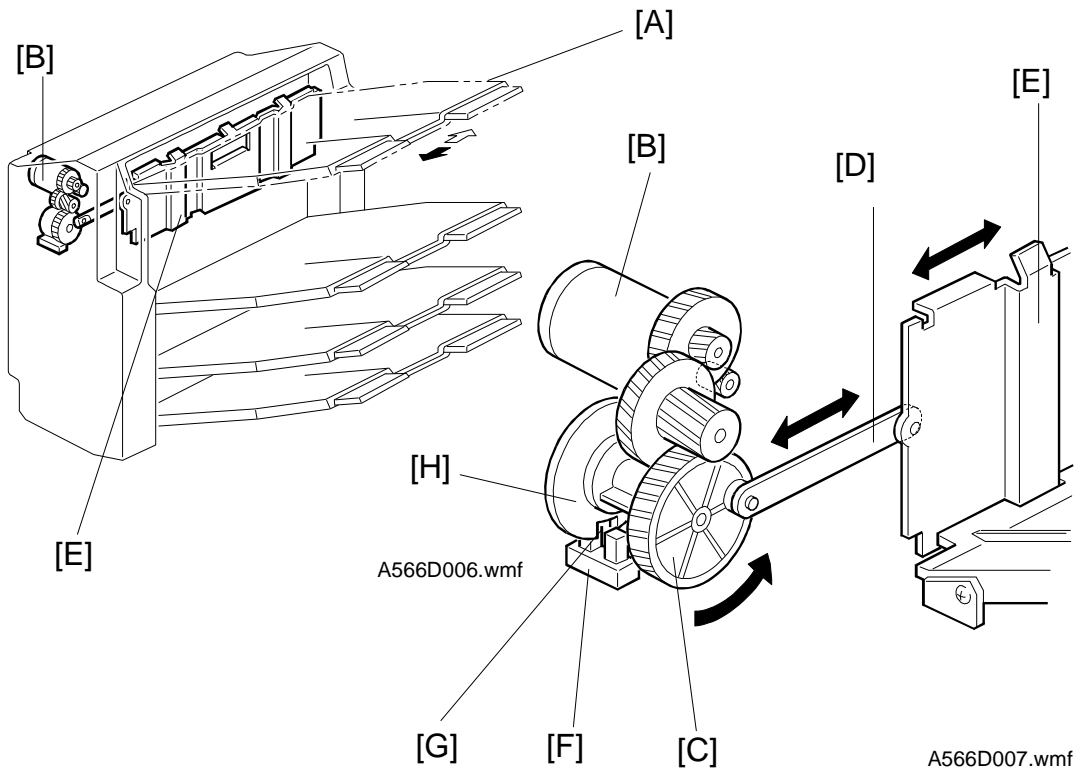

In the sort/stack mode, the 1st bin [A] moves from side-to-side to stagger and separate the sets of copies.

The horizontal position of the shift tray is controlled by the tray shift motor (a dc motor) [B] and the shift cam [C]. After one set of copies is delivered to the bin, the tray shift motor starts rotating, driving the shift cam through gears. The link [D] connected between the shift cam and the tray shift plate [E] is creating the side-to-side movement required to stagger the copies.

When the shift cam has rotated 180 degrees (when the tray is fully shifted across), the tray half-turn sensor [F] is activated by the slot [G] in the actuator plate [H], which is fixed to the shift cam, and the tray shift motor stops. The next set of copies is then delivered. The motor rotates, repeating the same process and moving the bin back to the previous position.

### 3.4 PAPER FEED AND MISFEED DETECTION TIMING

– Normal Mode –

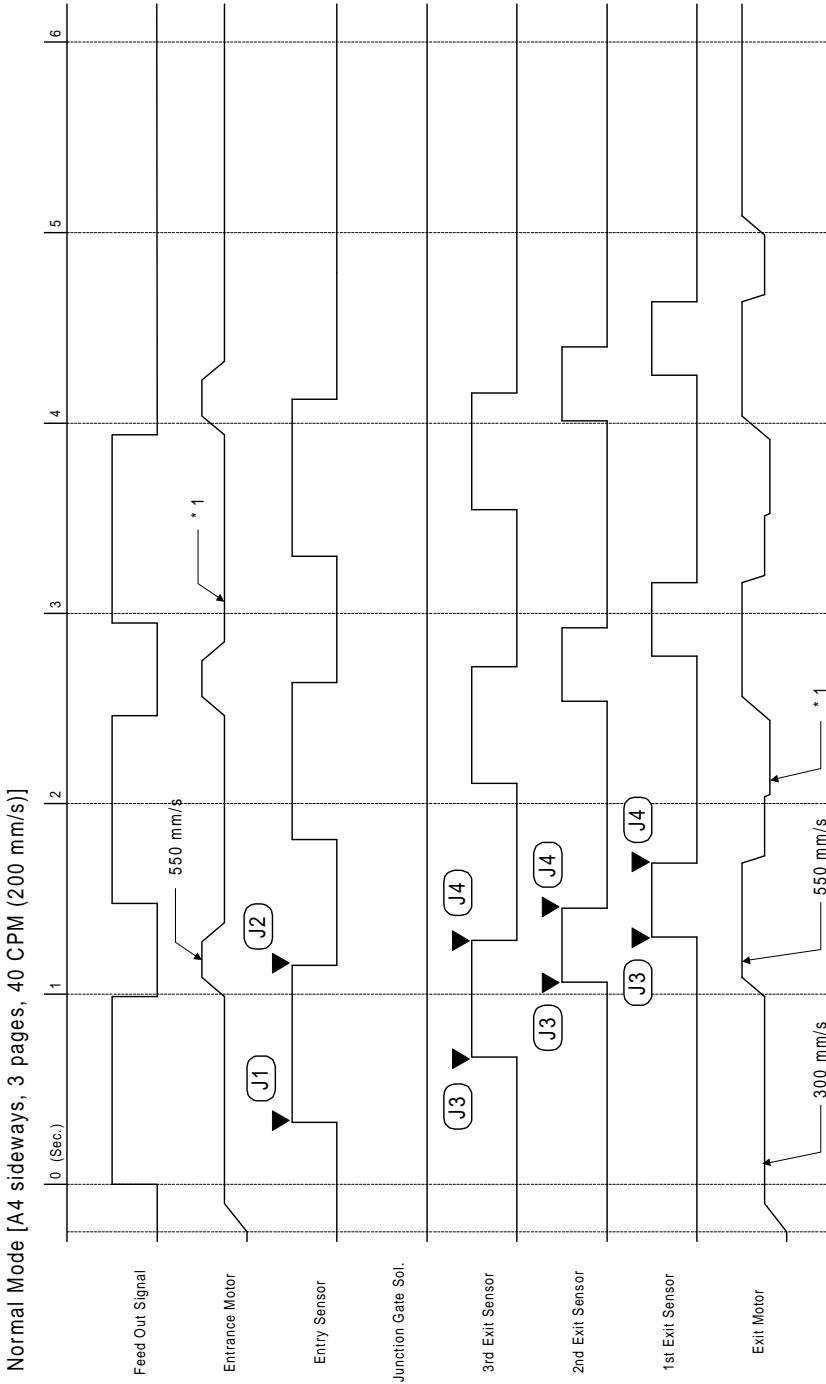

Normal Mode [A4 sideways, 3 pages, 40 CPM (200 mm/s)]

A566D008.wmf

\*1: This speed depends on the copier.

**- Inverter Mode -**

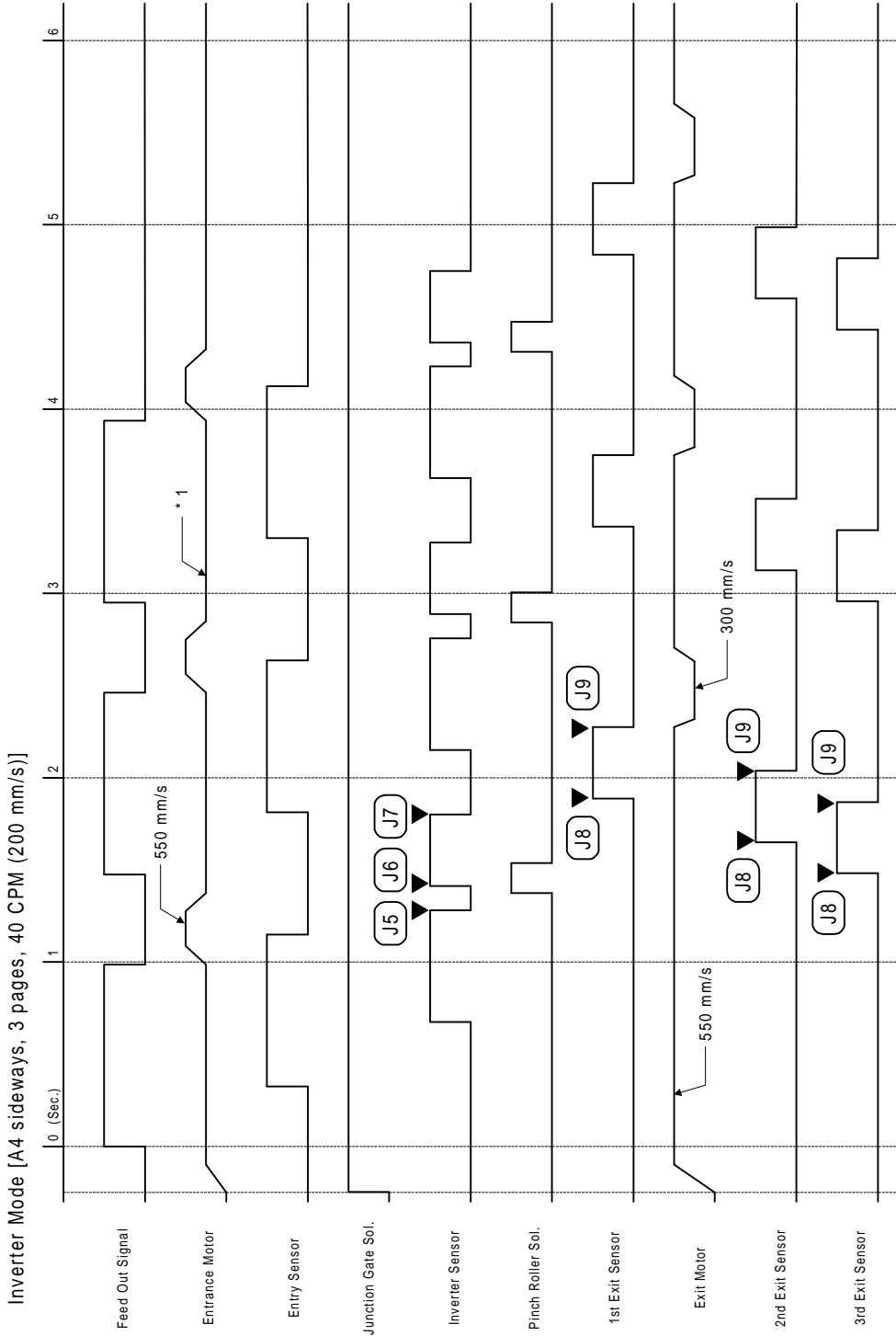

A566D009.wmf

\*1: This speed depends on the copier.

### 3.5 JAM DETECTION

#### – Paper Jams –

- J1: The entry sensor does not turn on within 2 s after the feed out signal has turned on.
- J2: The entry sensor does not turn off within 610 ms after the feed out signal has turned off or the entry sensor stays on over 2.8 s.
- J3: The following exit sensors do not turn on within the specified time after the entry sensor has turned on.
- 1st exit sensor: 2.4 s
  - 2nd exit sensor: 1.4 s
  - 3rd exit sensor: 740 ms
- J4: The following exit sensors do not turn off within the specified time after the entry sensor has turned off.
- 1st exit sensor: 870 ms
  - 2nd exit sensor: 500 ms
  - 3rd exit sensor: 270 ms
- J5: The inverter sensor does not turn off within 4.56 s after the inverter sensor has turned on.
- J6: The inverter sensor does not turn on again within 380 ms after the inverter sensor has turned off.
- J7: The inverter sensor does not turn off within 1.14 s after the inverter sensor has turned on again.
- J8: The following exit sensors do not turn on within the specified time after the inverter sensor has turned on again.
- 1st exit sensor: 770 ms
  - 2nd exit sensor: 430 ms
  - 3rd exit sensor: 250 ms
- J9: The following exit sensors do not turn off within the specified time after the inverter sensor turned off again.
- 1st exit sensor: 770 ms
  - 2nd exit sensor: 430 ms
  - 3rd exit sensor: 250 ms

---

## 4. INSTALLATION PROCEDURE

### 4.1 ACCESSORY CHECK

Check the quantity and condition of the accessories in the box against the following list.

1. New Equipment Condition Report .....	1
2. Installation Procedure .....	1
3. Front Connecting Bracket.....	1
4. Rear Connecting Bracket .....	1
5. Bottem Bracket .....	1
6. Copy Tray .....	4
7. Decal - Paper Size Detector .....	1
7. Philips Screw - M4X12 .....	6
9. Tapping Screw - M4X10 .....	2
10. Snap Ring .....	2

## 4.2 INSTALLATION PROCEDURE

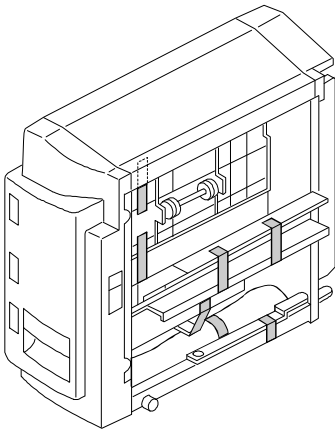

A566I500.wmf

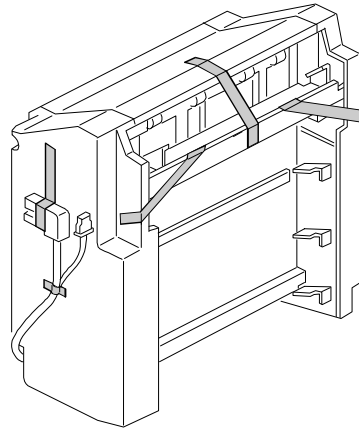

A566I501.wmf

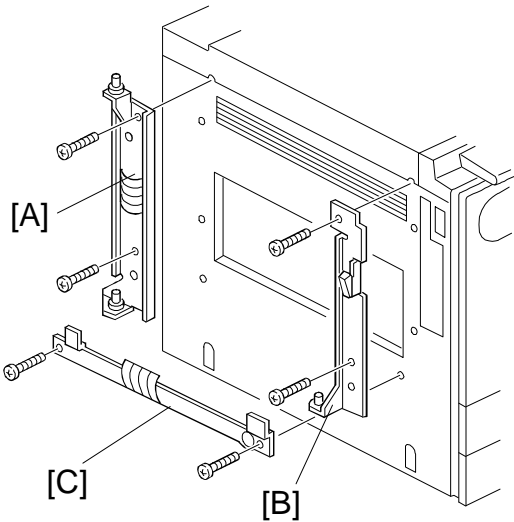

A566I502.wmf

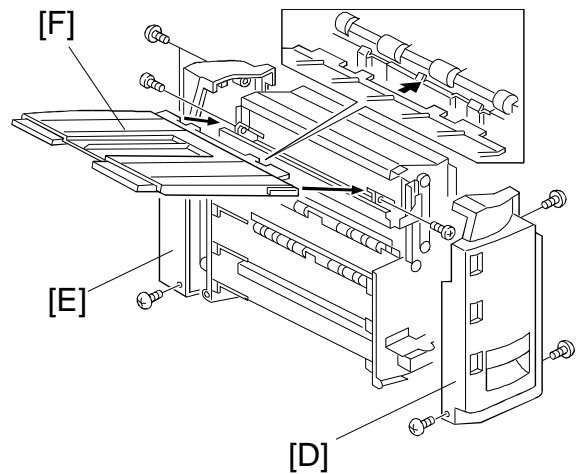

A566I503.wmf

### **⚠ CAUTION**

**Unplug the copier power cord before starting the following procedure.**

1. Remove the strips of tape.
2. Install the front connecting bracket [A] (2 screws) and the rear connecting bracket [B] (2 screws).
3. Install the bottom bracket [C].
4. Remove the front cover [D] (3 screws) and rear cover [E] (3 screws).
5. Install the tray [F] with 2 tapping screws - M4 x 10.

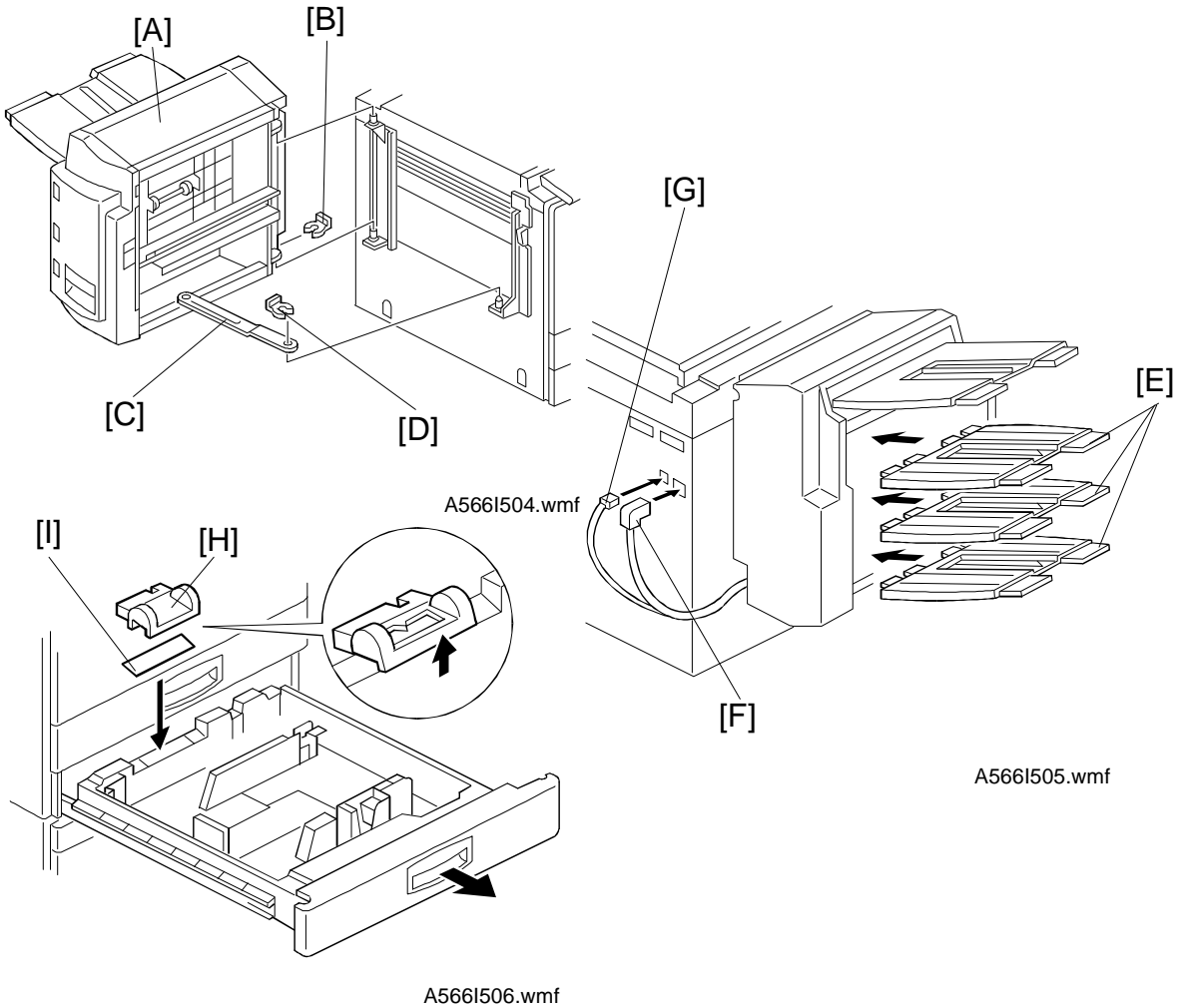

6. Install the sorter unit [A] on the frame with 1 clip [B].

7. Mount the arm bracket [C] with 1 clip [D].

8. Install the trays [E].

9. Reinstall the front and rear covers.

10. Connect the cable [F] and the optic cable [G].

**NOTE:** If the main machine is 115V version, perform the following. In other case, skip step 11.

11. Remove the slider [H] from the copier's paper tray and attach the paper size detection decal [I].

12. Reinstall the slider.

13. Turn the copier's main switch on and check the sorter operation.

## 5. REPLACEMENT AND ADJUSTMENT

### 5.1 EXTERIOR COVER AND BIN REMOVAL

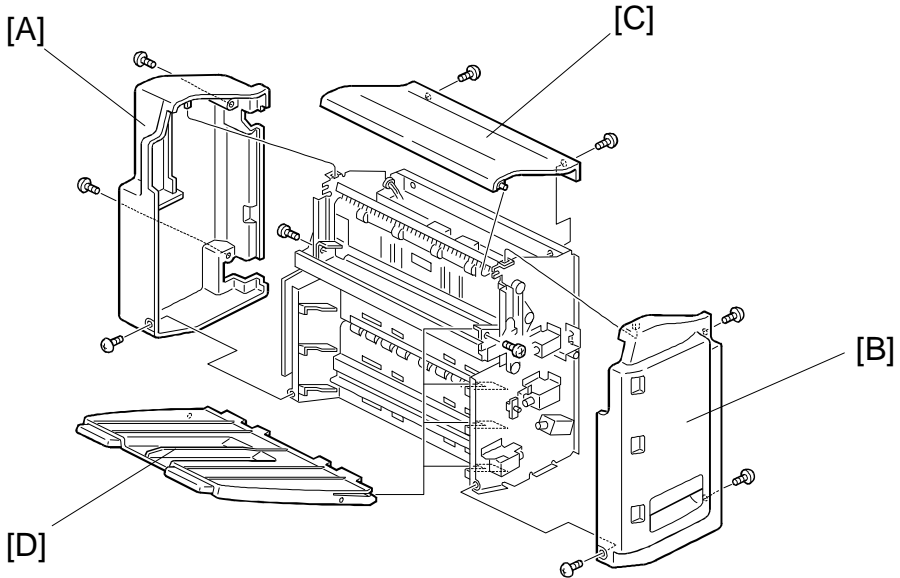

A566R006.wmf

1. Rear Cover [A] (3 screws)
2. Front Cover [B] (3 screws)
3. Top Cover [C] (2 screws)
4. Bins [D] (1st bin: 2 screws)



## 5.2 TRAY LIFT/TRAY SHIFT MOTOR ASSEMBLY REMOVAL

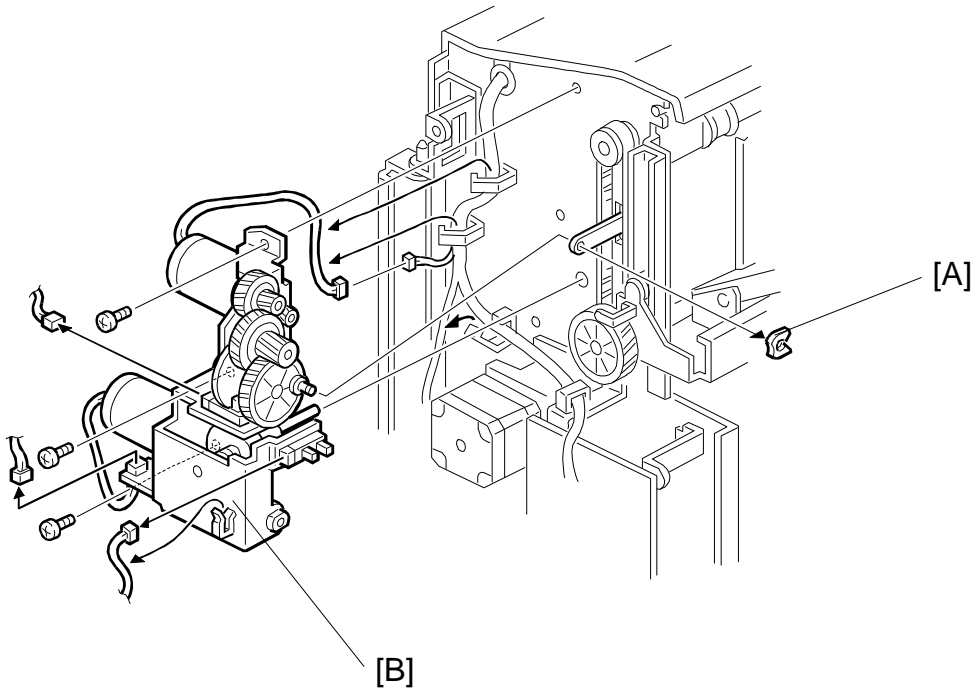

A566R007.wmf

1. Remove the rear cover (see Exterior Cover and Bin Removal).
2. Remove the clip [A].
3. Remove the motor assembly [B] (3 screws, 3 connectors).

### 5.3 ENTRANCE MOTOR REPLACEMENT

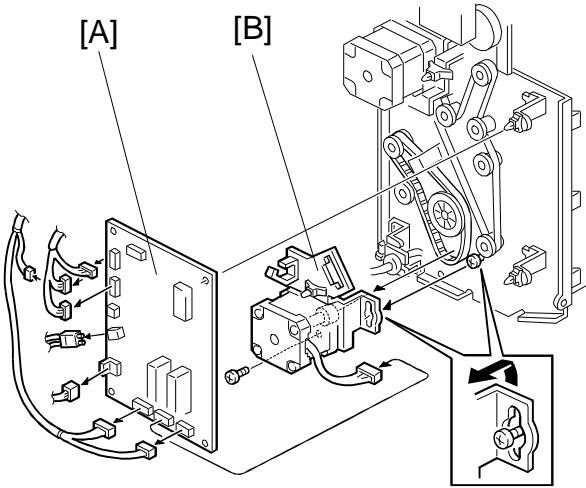

A566R008.wmf

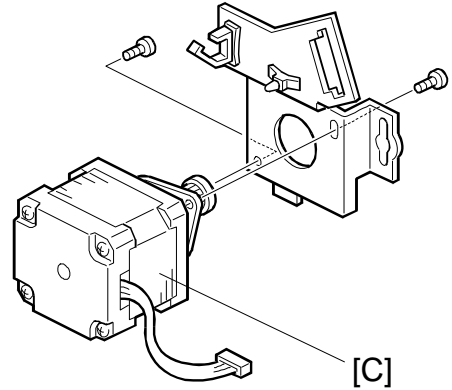

A566R009.wmf

1. Remove the rear cover (see Exterior Cover and Bin Removal).
2. Remove the control board [A] (9 connectors, 4 clamps).
3. Remove the motor bracket [B] (2 screws).
4. Remove the exit motor [C] (2 screws).

## 5.4 EXIT MOTOR REPLACEMENT

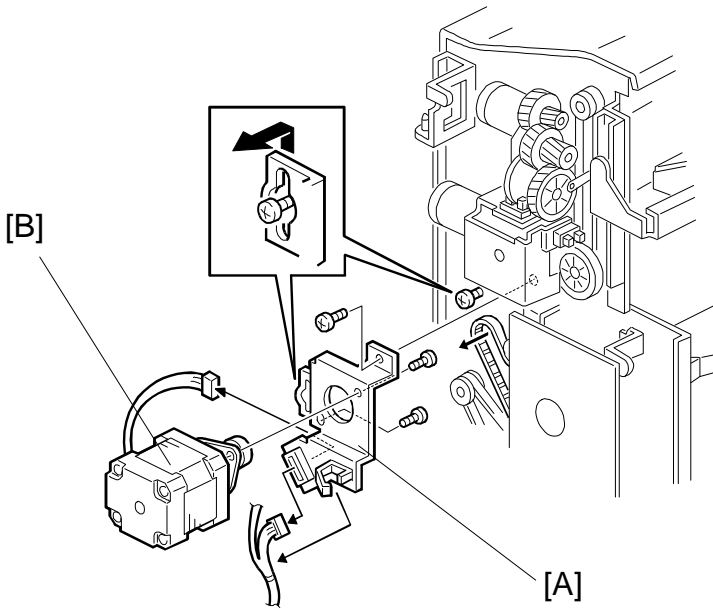

A566R010.wmf

1. Remove the rear cover (see Exterior Cover and Bin Removal).
2. Remove the motor bracket [A] (2 screws, 1 connector).
3. Remove the exit motor [B] (2 screws, 1 connector).

## 5.5 STACK HEIGHT SENSOR AND 1ST EXIT SENSOR REPLACEMENT

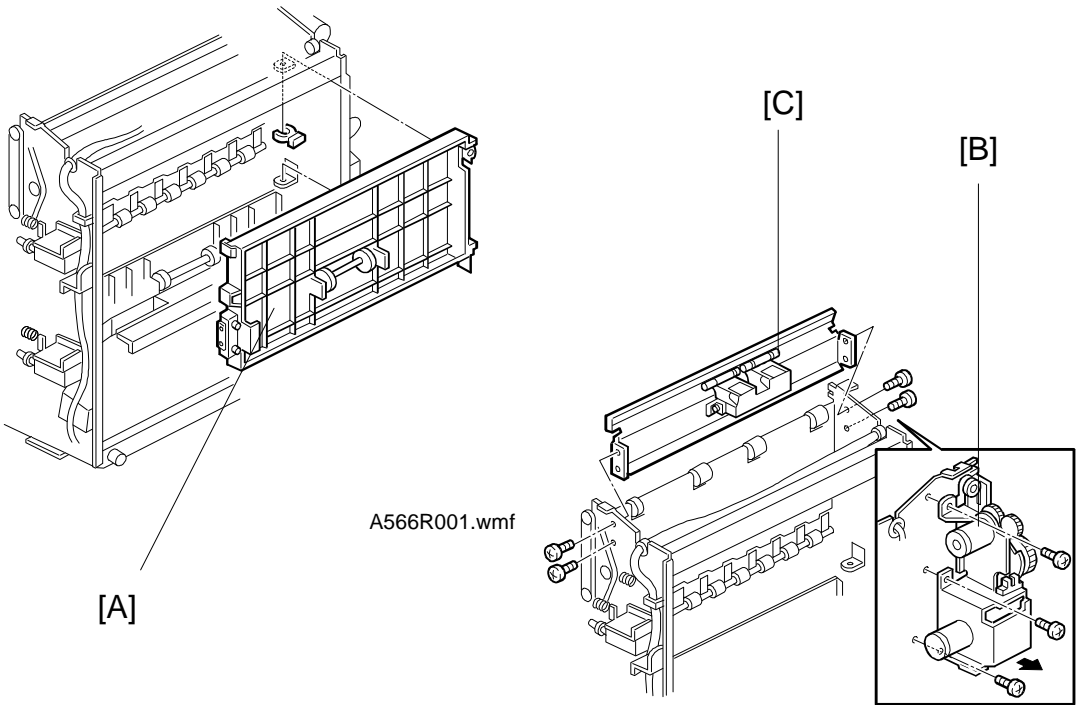

A566R001.wmf

A566R002.wmf

1. Remove the front, rear, and top covers (see Exterior Cover and Bin Removal).
2. Remove all bins (see Exterior Cover and Bin Removal).
3. Remove the 3-bin sorter.
4. Remove the middle guide plate [A] (1 clip).
5. Remove the motor assembly [B] (see Tray Lift/Tray Shift Motor Assembly Removal).
6. Remove the upper guide plate [C] (4 screws).

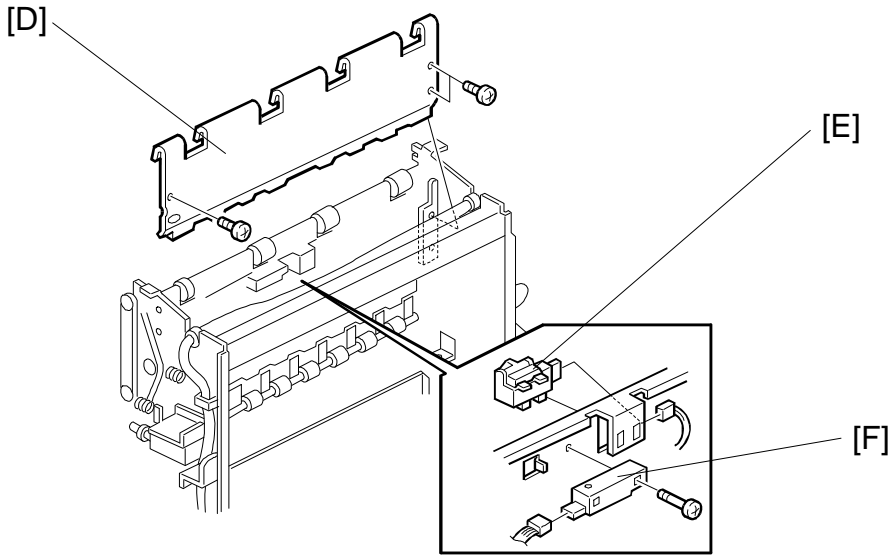

A566R003.wmf

7. Remove the middle shift guide plate [D] (3 screws).
8. Remove the stack height sensor [E] (1 connector).
9. Remove the 1st exit sensor [F] (1 screw, 1 connector).

## 5.6 2ND / 3RD EXIT SENSOR AND INVERTER SENSOR REPLACEMENT

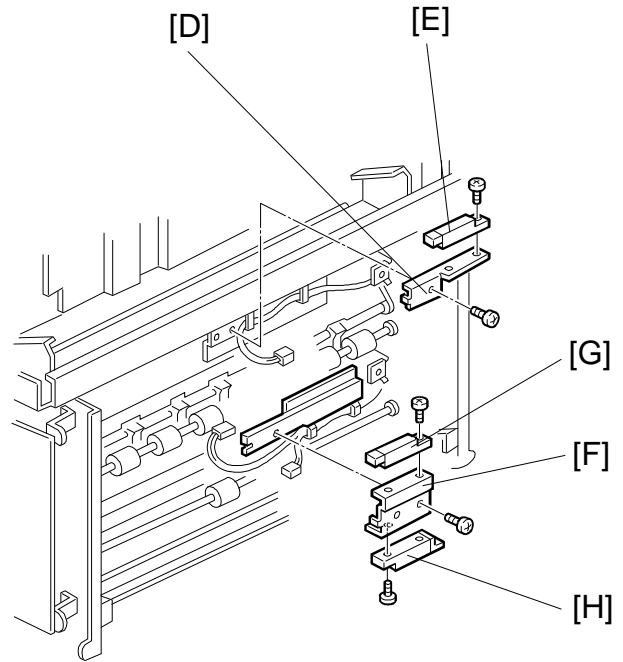
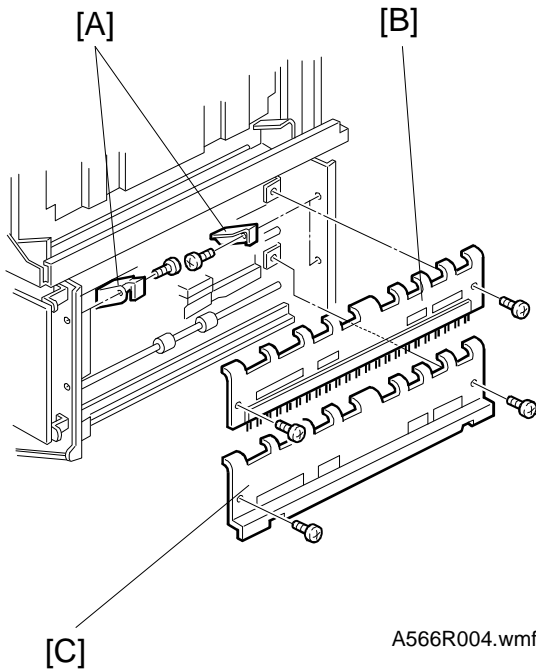

1. Remove the front cover and rear cover (see Exterior Cover Removal).
2. Remove all bins.
3. Remove four tray brackets [A] (1 screw each).
4. Remove the upper exit cover [B] (2 screws).
5. Remove the lower exit cover [C] (2 screws).
6. Remove the sensor bracket [D] (1 screw) and replace the 2nd exit sensor [E] (1 screw, 1 connector).
7. Remove the sensor bracket [F] (1 screw) and replace the 3rd exit sensor [G] (1 screw, 1 connector).
8. Replace the inverter sensor [H] (1 screw, 1 connector).